



Diffraction II

Physics 2415 Lecture 38

Michael Fowler, UVa

Today's Topics

- Multi-slit interference
- The diffraction grating: spectra
- Waves and particles, more diffraction
- Radio astronomy

Reminder!

Light Intensity Pattern from Two Slits

- We have two equal-strength rays, phase shifted by

so the total electric field is

$$\begin{aligned} E_{\text{tot}} &= E_0 \sin \omega t + E_0 \sin (\omega t + \delta) \\ &= 2E_0 \sin \left(\omega t + \frac{1}{2} \delta \right) \cos \left(\frac{1}{2} \delta \right) \end{aligned}$$

and the intensity $\propto \overline{E_{\text{tot}}^2}$ is:

$$I(\theta) = I(0) \cos^2 \left(\frac{\delta}{2} \right) = I(0) \cos^2 \left(\pi \frac{d \sin \theta}{\lambda} \right)$$

What happens if we go to *three* slits?

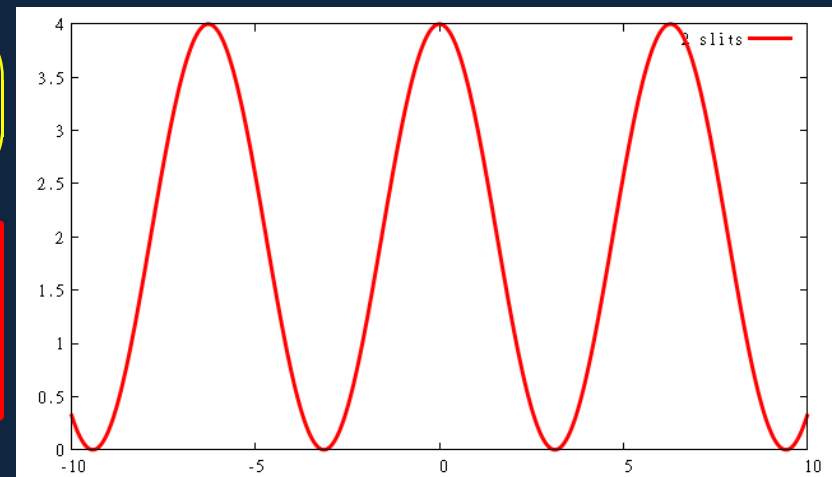
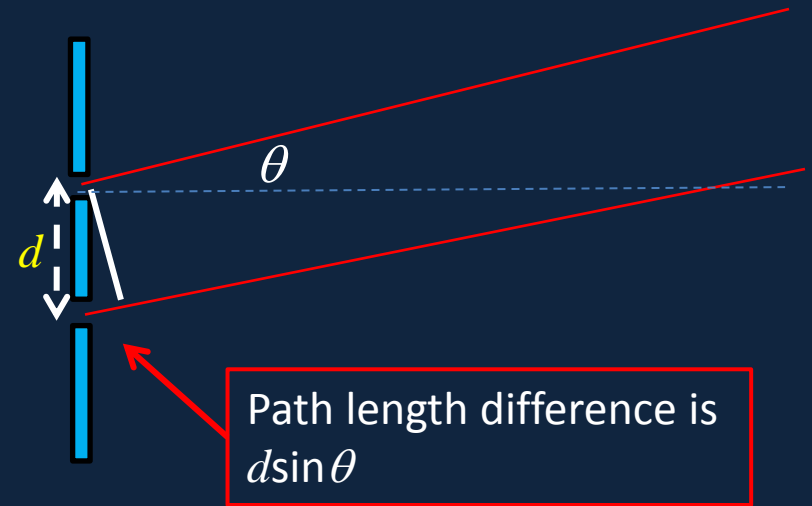

Light Intensity Pattern from Three Slits

- If the path difference from adjacent slits to a point on the screen is a whole number of wavelengths, all three will add.
- If the path difference is an odd number of half wavelengths, two slits will cancel, but the third will be untouched—the electric field at the screen will be $1/3$ its maximum value, intensity $1/9^{\text{th}}$.

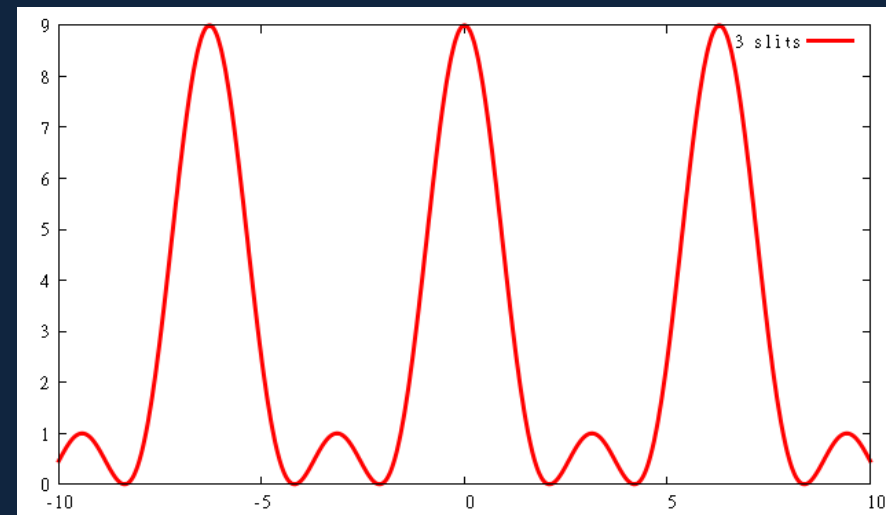
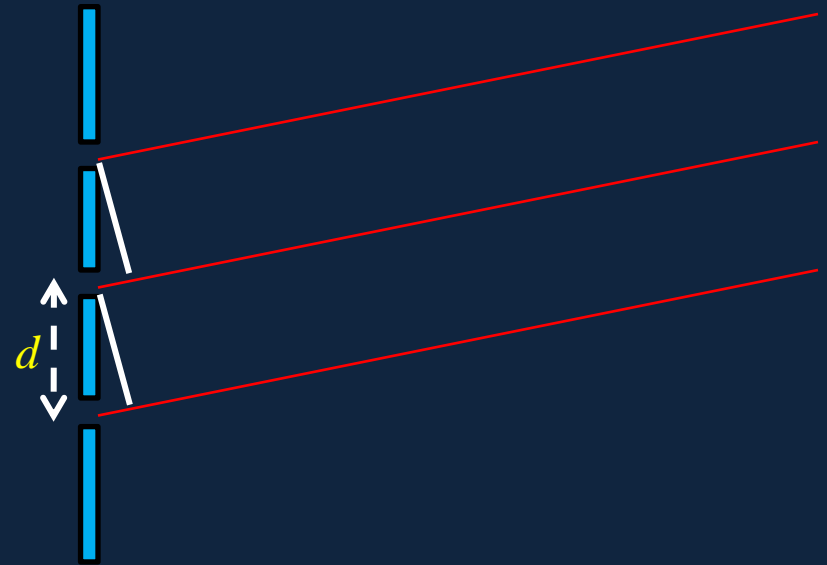

More Slits...

- When the path difference between adjacent slits is a whole number of wavelengths, all the slits add.
- The intensity is more and more concentrated in narrow peaks at these values.

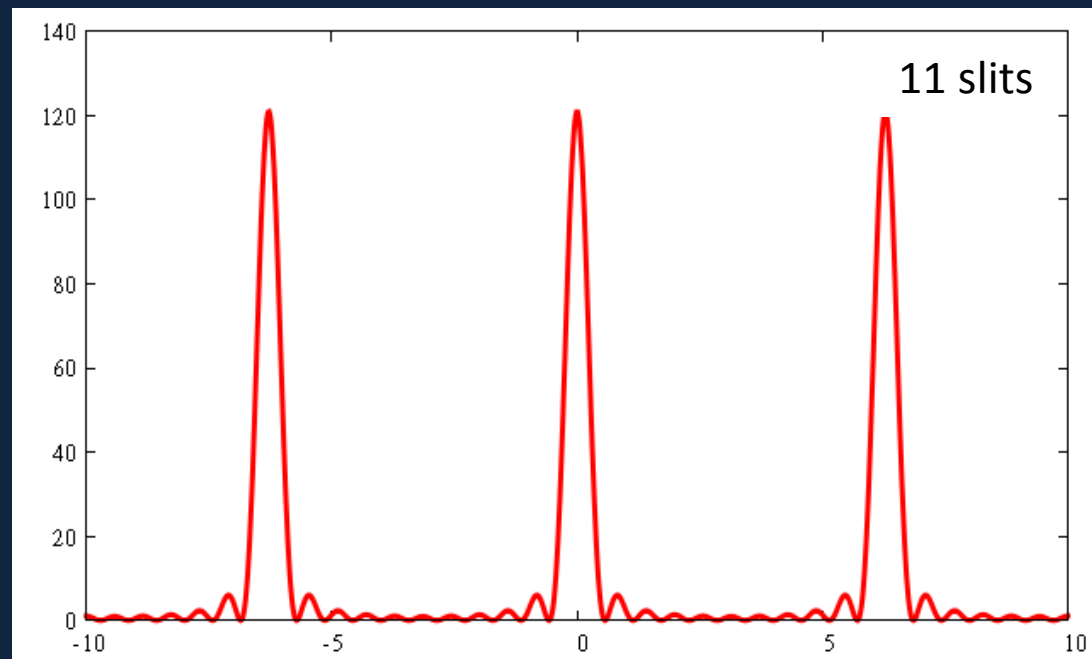
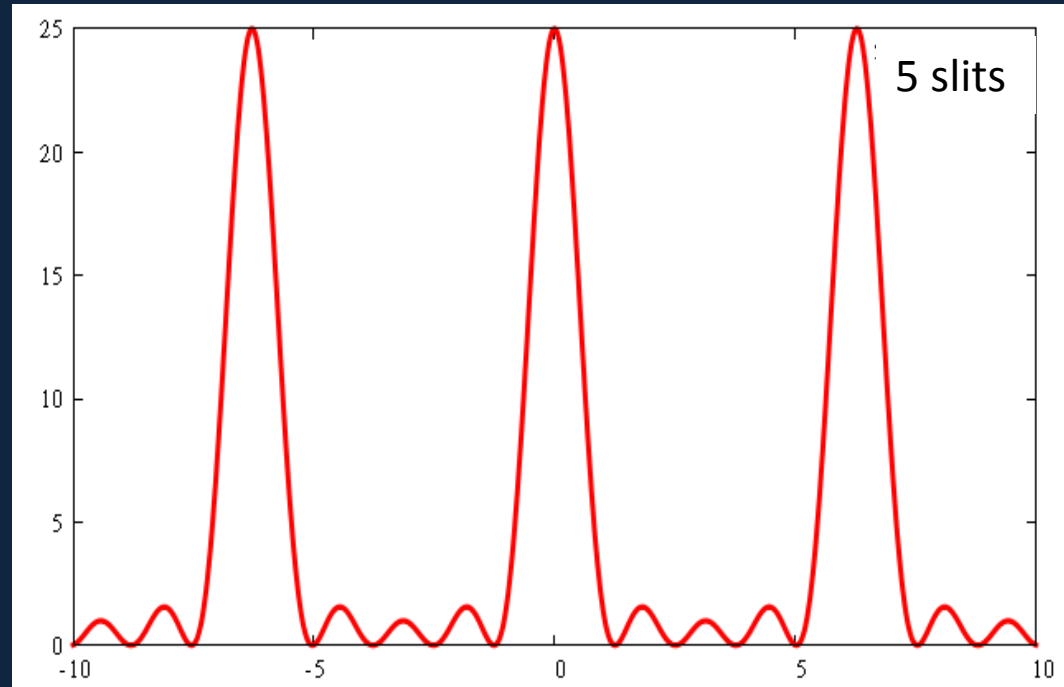

Diffraction Grating

- A diffraction grating consists of **many** equally spaced parallel slits. Typically it has **thousands** of slits per centimeter.
- This ensures that a substantial fraction of the incident light goes through, and also that **the angle of scattering is very precisely given as a function of wavelength.**
- There are **reflective** diffraction gratings: a CD or DVD has many parallel lines (actually of course arcs of circles) but the effect is evident.

Clicker Question

- A diffraction grating has 6.0×10^5 lines/m.
- Red light has wavelength 7.0×10^{-7} m and blue light wavelength 4.5×10^{-7} m.
- Using white light, this grating produces complete first and second order spectra.
- **Beyond that,**
 - A. It produces no more spectra
 - B. It produces part of a third order spectrum
 - C. It produces a complete third order spectrum, possibly more.

Clicker Question

- A diffraction grating has 6.0×10^5 lines/m.
- Red light has wavelength 7.0×10^{-7} m and blue light wavelength 4.5×10^{-7} m.
- Using white light, this grating produces complete first and second order spectra.
- **Beyond that,**

A. It produces no more spectra

➔ B. It produces part of a third order spectrum

The formula $\sin \theta = 3\lambda/d$ gives $\sin \theta_{\text{blue}} < 1$, $\sin \theta_{\text{red}} > 1$.

Spectra

- It's easy to check with the diffraction grating that **a very hot wire radiates at all visible frequencies**—but, if it's just hot enough to be seen, the light is reddish.
- A hot gas, like **hydrogen** stimulated by electrical discharge, **emits at a small number of frequencies**, as shown here.
- All gas molecules have “**line spectra**” with definite frequencies—hydrogen is the simplest, with just the four (visible) lines shown.

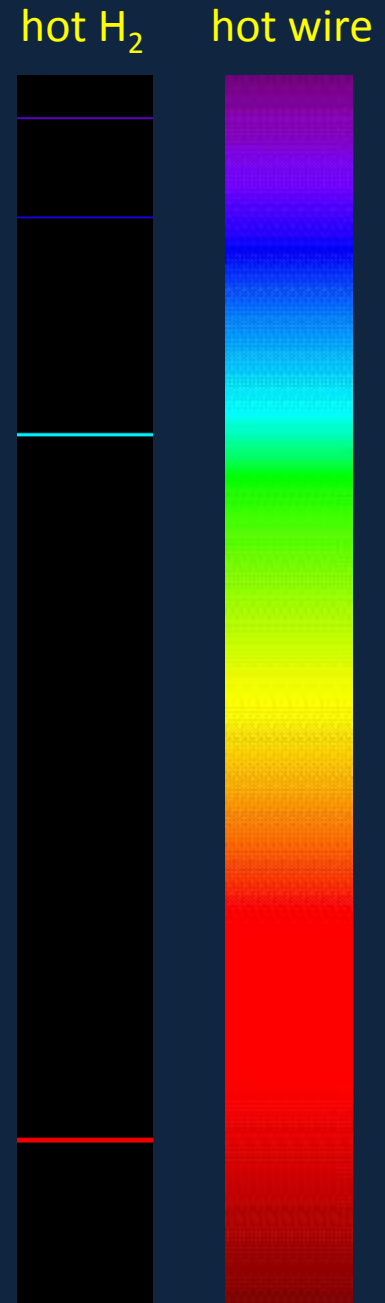

Photons: the Nature of Light

- Experimentally, it is found that although light **propagates like a wave**, when light is absorbed (photoelectric effect, for example) or emitted (spectra) it acts like **tiny packets of energy**, called **photons**.
- For light of frequency f , each photon has energy hf , h is Planck's constant, 6.63×10^{-34} J.sec.
- Light of energy E has momentum $p = E/c$, so a photon has momentum $p = hf/c = h/\lambda$.

Clicker Question: LED's

- In an LED, the potential energy delivered to an electron by the battery is emitted as a single photon.
- Arrange a red LED, yellow LED and blue LED in order of **increasing** voltage required:

A. RYB

B. BYR

C. BRY

D. RBY

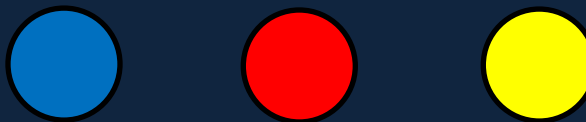

The Hydrogen Atom

- The H atom has a nucleus, a single proton, and a single electron circling around it like a planet—the attraction is inverse square, just like gravity, so the orbits are the same.
- On heating the atoms, the electron will be knocked about in atomic collisions, and will emit radiation as it spirals back to lower orbits.
- **BUT very few colors are observed!** So very few different energies can be emitted—only **very few circular orbits are allowed** for some reason...

De Broglie's Idea

- It's hard to see why a little charged particle like the electron should only be allowed to circle the proton at certain radii. **Planets don't have this problem.**
- De Broglie knew the **photon's** particle-like momentum was related to its wavelength $p = h/\lambda$.
- He suggested that the **electron must have a wavelength**, with the **same** relationship $p = h/\lambda$.
- Then the allowed orbits might be those where you could **fit a standing wave around the circle.**

De Broglie's Electron Waves

- Putting together the orbit formula $mv^2/r = ke^2/r^2$ with $p = h/\lambda$, and fitting a whole number of λ 's around $2\pi r$ gives a set of allowed orbits, hence allowed energies.
- Assuming the excited atom emits **one** photon as it drops to a lower orbit, the colors of predicted photons correspond exactly with the observed hydrogen spectrum.
- **So the electron is a wave!**

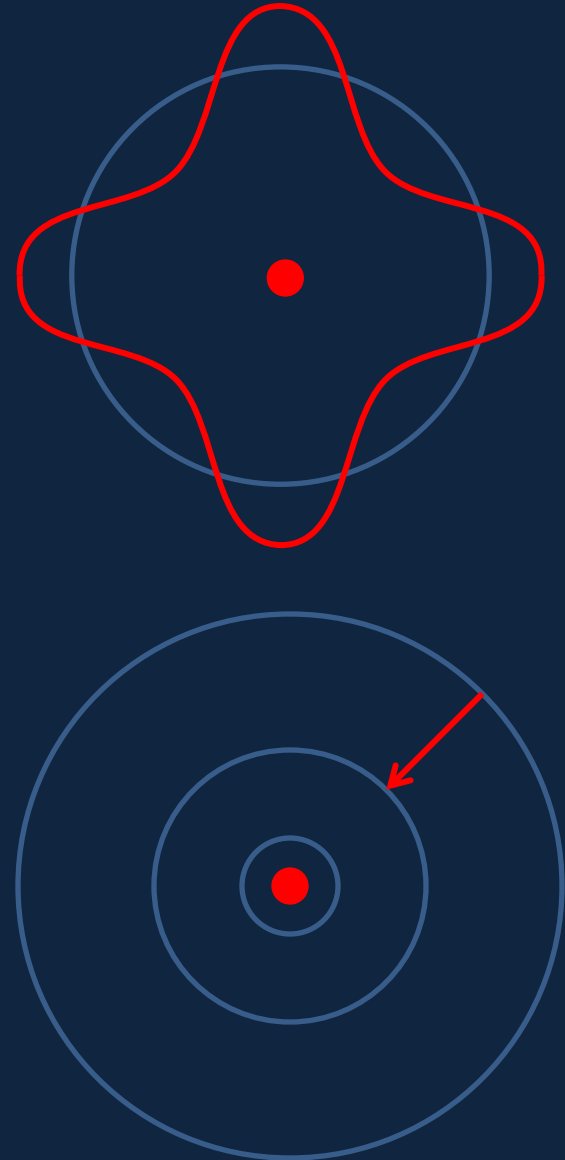

Wave Nature of the Electron

- The wave nature of the electron was first observed directly by Davisson and Germer at Bell Labs in New Jersey.
- They observed interference patterns (like soap film colors) between reflections from different layers of atoms in a nickel crystal.
- Davisson went on to be a physics prof at UVa.

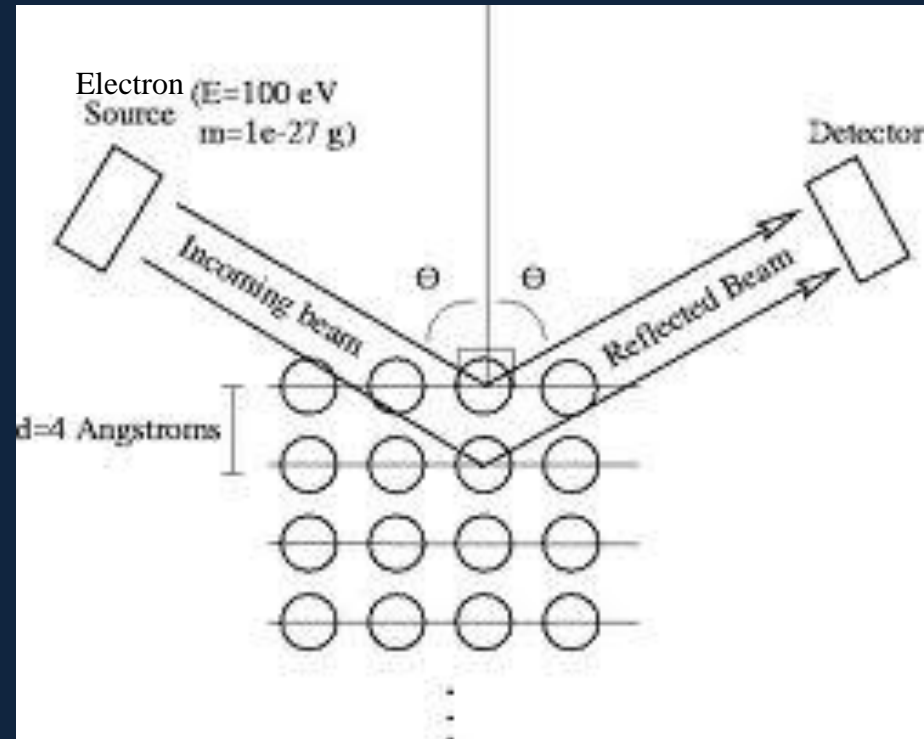

Electron Diffraction

- A stream of electrons hits a thin piece of graphite, made of many small crystals.
- The electrons are diffracted through definite angles, depending on the electron wavelength—which varies with energy.

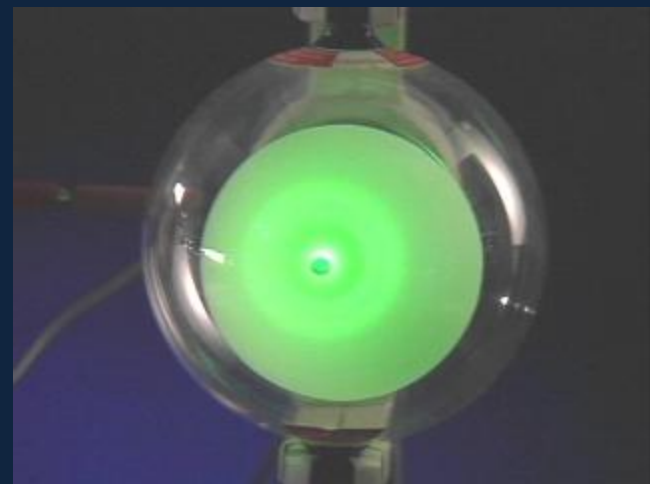
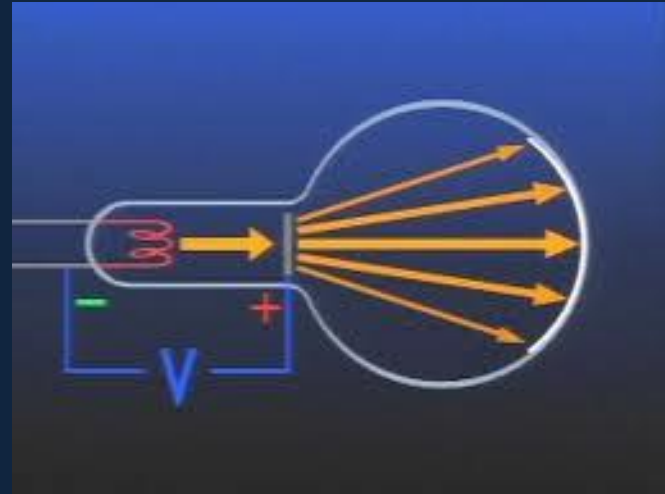

Neutrons are Waves too...

- Here's the structure of a ferroic, a new material with linked electric and magnetic properties likely to be useful commercially.
- Its structure was found by scattering **neutrons** off of it like a three dimensional diffraction grating. Using $p = h/\lambda$ gives the correct neutron wavelength.

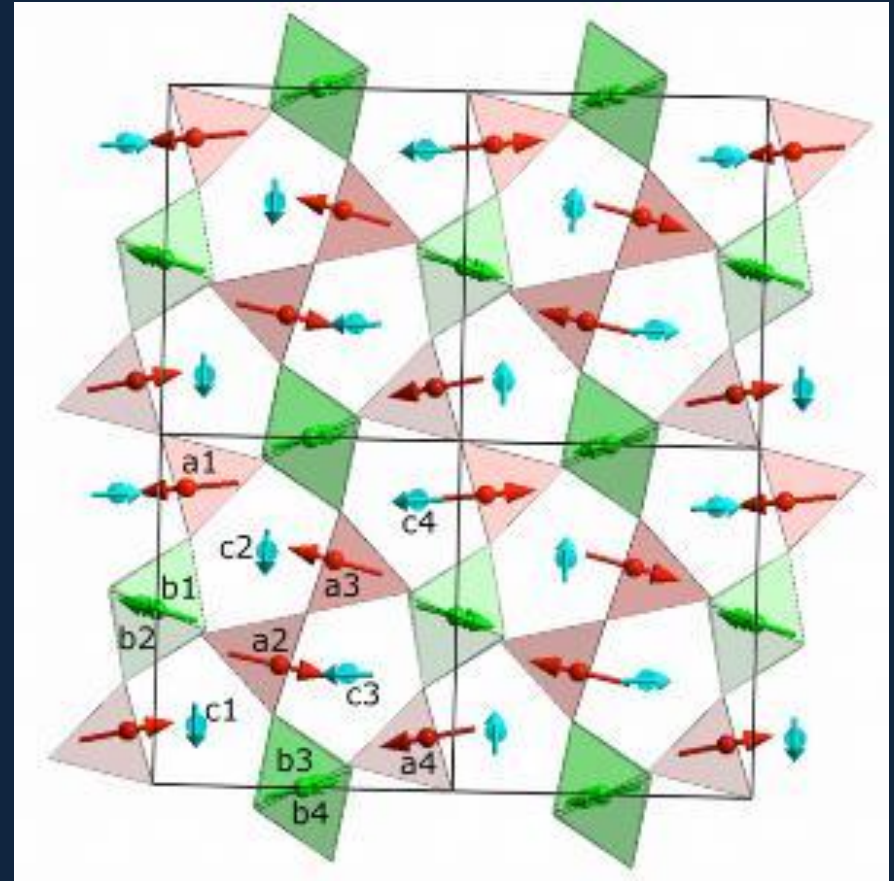

Even *Molecules* are Waves!

- This is a **Poisson Spot** from a stream of D_2 molecules aimed at a small disk—it proves that the D_2 molecules had a well-defined wavelength, and diffracted as predicted.

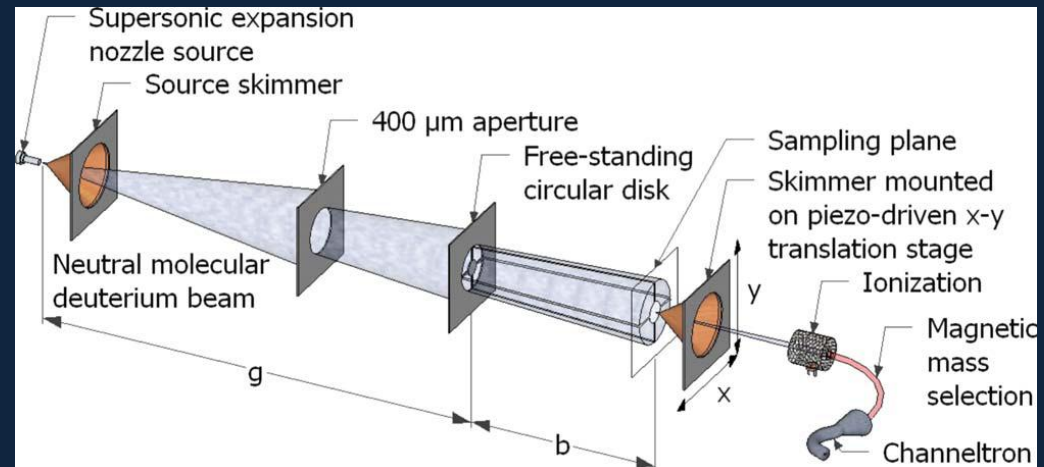
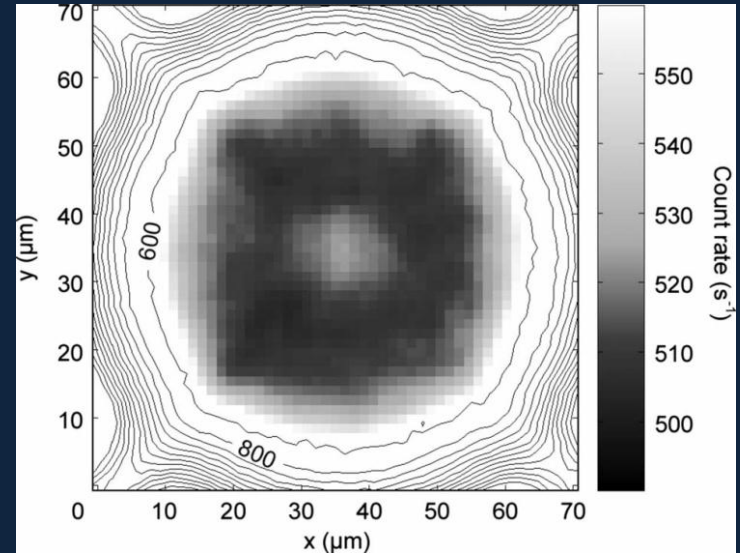

X-Ray Diffraction

- X rays are electromagnetic radiation with wavelength comparable to interatomic spacing in molecules and crystals. They can be diffracted from planes of atoms in crystals, the diffraction pattern can be used to construct a model of the crystal structure.

Note: x rays and neutrons are both used for crystals. Neutrons are sensitive to hydrogen, x rays are not. Also, neutrons can detect magnetic structure. But x rays are much less expensive.

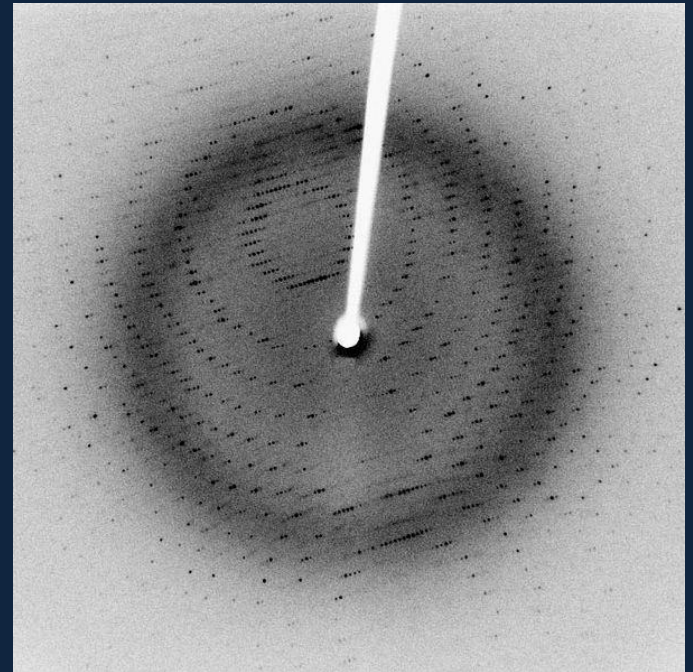

This is diffraction from a crystal of 3Clpro, a SARS protease. Finding its exact structure is a crucial step in designing effective drugs against this disease.

Radio Astronomy

- Many stars, gas clouds, etc., emit radio waves—and these can teach us a lot about the universe.
- However, **the wavelengths are so long that big receivers are needed to get good angular resolution.** This one (in West Virginia) weighs 7300 tons.



The receiver has diameter about 100m. Radio waves of wavelengths from 30 cm down are studied. Angular resolution around 0.15° .

Big Diffraction Grating...

- This is really a diffraction grating in reverse—the signals from all the receivers are brought together, those with the right phase matching all come from the same direction.
- But there's more...



The effective D is the length of the line of telescopes.